

MANEUVER SCHEDULE

Spin check required for all zero-speed maneuvers.

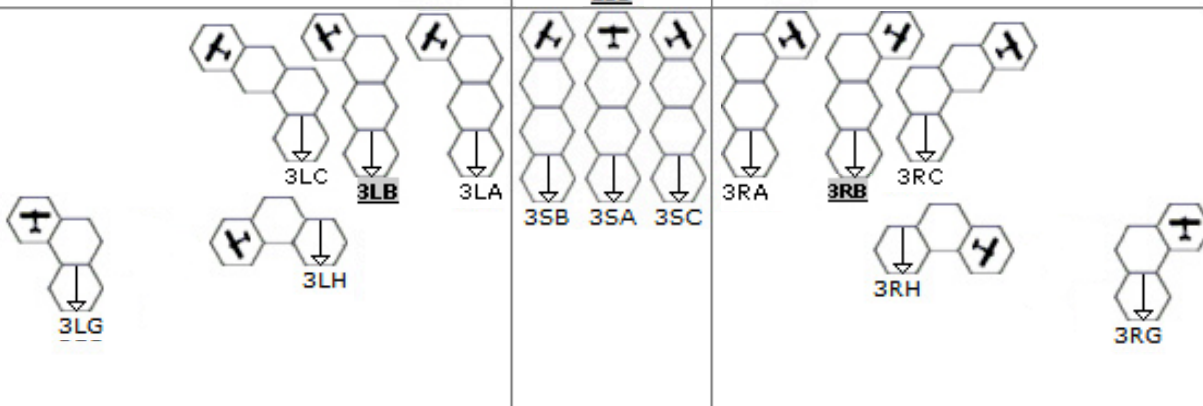
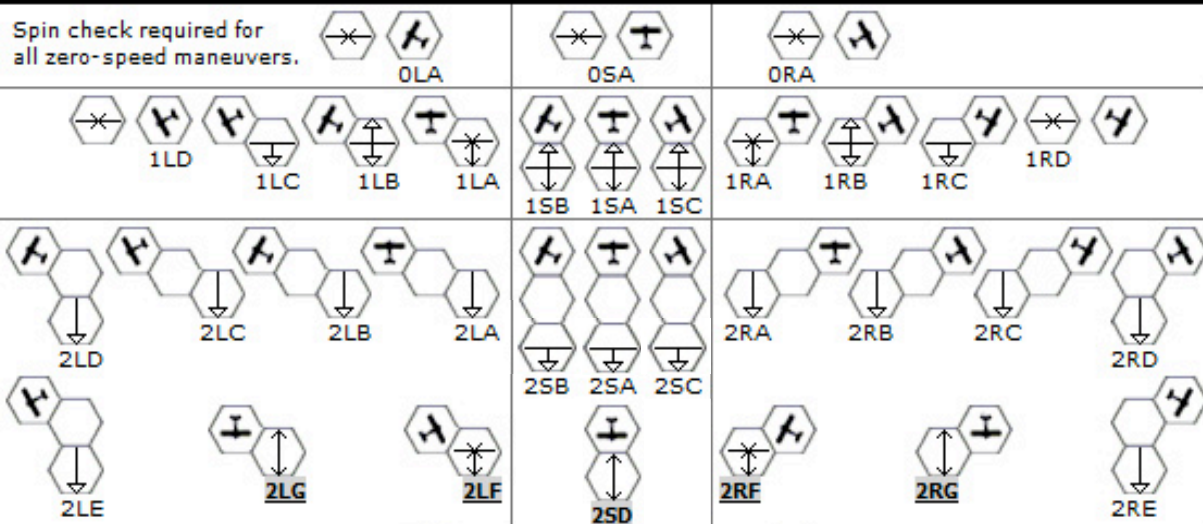

↗ May climb max ↖ May climb 1-2 ↑ May climb 1 — Level flight allowed ↓ May dive 1 ⇩ May dive max ▼ MUST dive 2+ ✕ Level this turn but MUST dive next turn

Turn	Man.	Alt
1		
2		
3		
4		
5		
6		
7		
8		
9		
10		
11		
12		
13		
14		
15		
16		
17		
18		
19		
20		
21		
22		
23		
24		
25		
26		
27		
28		
29		
30		
31		
32		
33		
34		
35		

Gloster Gladiator MkII

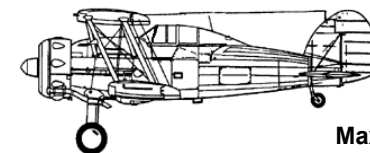

Max Alt: 11

PERFORMANCE

Acceleration	2
Deceleration	2
Climb	2
Dive	2

FIREPOWER

Weapon	Arc	Trv	Range in Hexes			
			1	2	3	4
4 x .303 MG	1	↕	4	3	2	0

Ammo: □□□□ □□□□ □□□□

DAMAGE

Engine 1	□□□□ □□□□ ○○
Wings:	□□□□ □□□□ □□□□ □□□□ ○○○○ ○
Fusel.:	□□□□ □□□□ □□□□ □□□□ ○○○○ ○○
Pilot	M S D

NOTES

No pilot armor, +1 to all "Crew Wound" rolls.